

Line Scan Telecentric Lens

Model	VS-LTC5-50CO-28/F
Optical Mag.	× 5.0 ± 5 %
FOV	5.7 mm
WD	51.5 mm ± 2.5
O/I (Object & Imager Distance)	219.9 mm
Working F/#	25.0
NA	0.100
DOF at PCoC $\phi$ 0.04mm	0.08 mm
TV Distortion	0.08 %
Wavelength	Visible
Mount	F-Mount
Flange Back	46.5 mm
Image Circle	$\phi$ 28.6 mm
Co-Axial Prism	Built-in
Weight (approx.)	185 g
Dimension	$\phi$ 59 (max.) × L = 121.9 mm

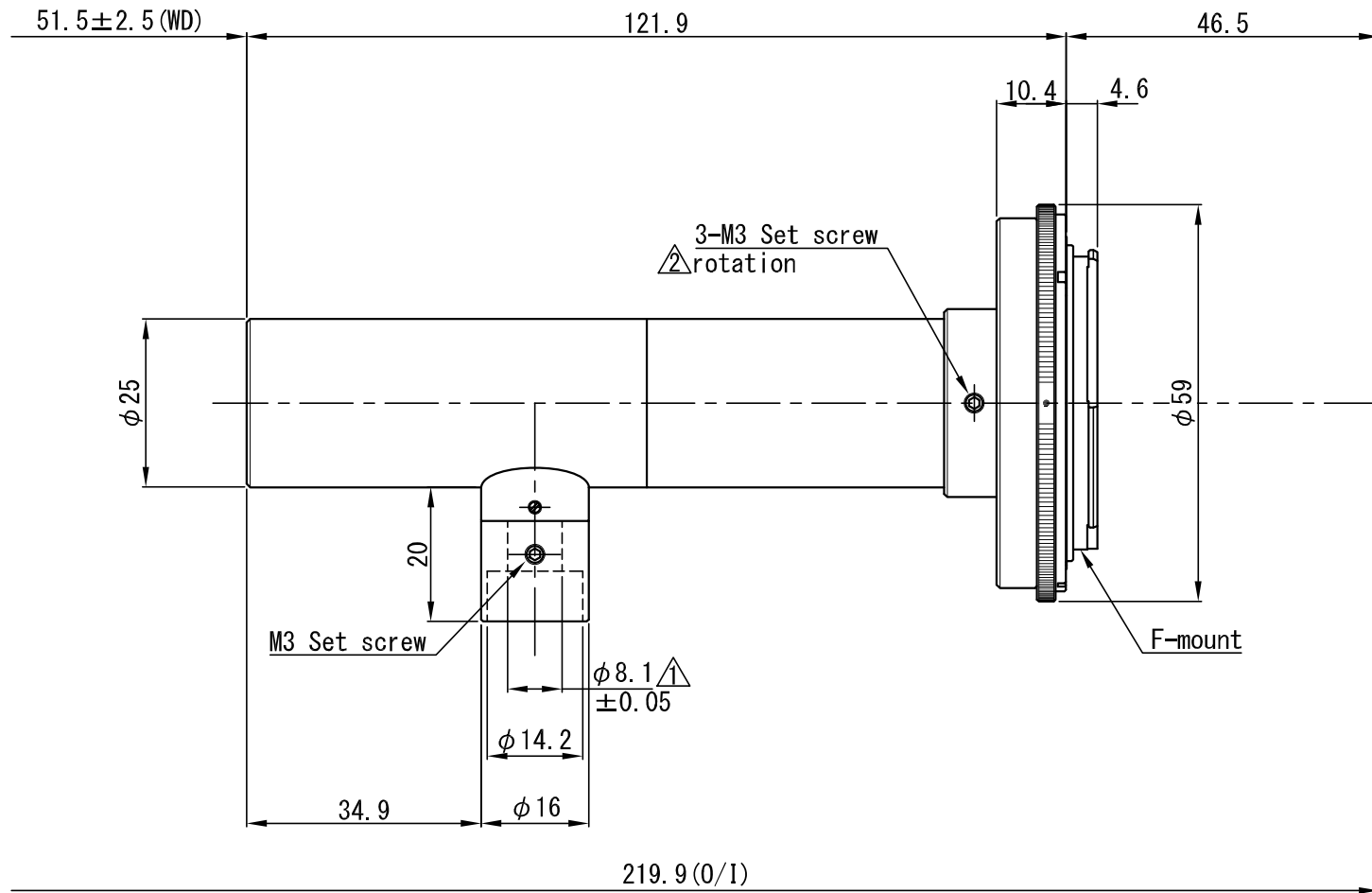

△×				APPROVED	CHECKED	MATERIAL 材料	-	CHAMFER 一般面取	-	QUANTITY 個数
△×				T. A.	T. A.	TREATMENT 処理	-	FINISHING 仕上	-	
△×						TREATMENT CONTACT 処理接点	-	DECENTRATION 偏芯	-	-
△× 1	rotation 表記追加	19.03.03	T. F.	DESIGNED	DRAWN	OVER 250 UP TO 1000	±0.3 ±0.5 ±1.0 ±0.2	ANGLE 角度	METHOD 図法	REMARK 適用 (機種名)
△× 1	φ8(+0.02/0) → φ8.1(±0.05)	18.08.29	S. U.	T. T.	T. T.	OVER 63 UP TO 250	±0.2 ±0.3 ±0.6 ±0.15	UNIT (mm)	⊕	V S - L T C 5 - 5 0 C 0 - 2 8 / F
NO.×箇所	REVISION 訂正事項	DATE	NAME			OVER 16 UP TO 63	±0.1 ±0.2 ±0.4 ±0.1	SCALE	1 / 1	NAME
						OVER 0 UP TO 16	±0.05 ±0.1 ±0.2 ±0.1	DATE	11.05.18	DRAW NO.
						TOLERANCES	A B C S			0 D T C 0 1 2 9 A 3