

Mega Pixel CCTV Lens

Model	SV-5026H
Focal Length (f)	50 mm (49.99)
Maximum Aperture Ratio	1:2.6 (2.66)
F/#	2.6 ~ Close
Angle of view (2/3")	7.6° X 10.1° (Diagonal: 12.6°)
M.O.D	500 mm
Back Focus	25.78 mm
Flange back	17.526 mm
Operation of Iris & Focus	manual
Mount	C-mount
Filter Thread	M 27 P= 0.5
Front Principle Point	12.36 mm
Rear Principle Point	-24.20 mm
FPP RPP Distance	-8.50 mm
Optical over all length	28.06 mm
Wavelength	Visible (400nm - 700nm)
Sensor size (max.)	2/3"
Weight (approx.)	53.0 g
Dimension	Φ 29 (MAX) × L= 39.0 mm

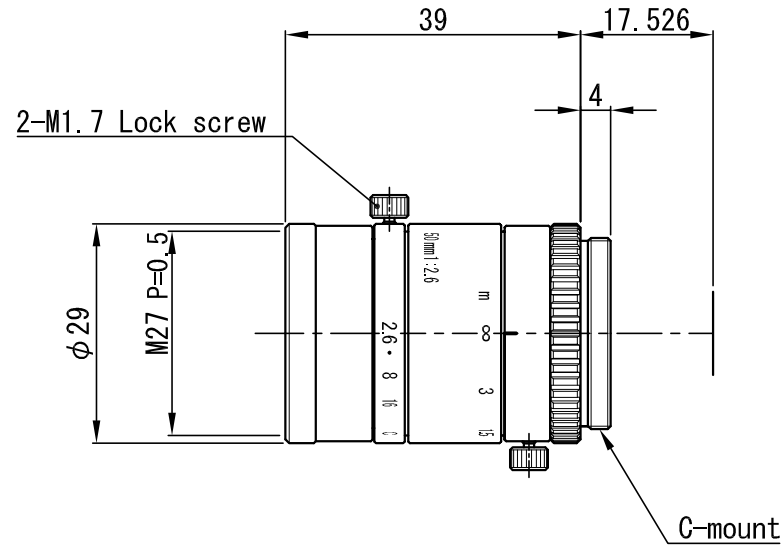

△				APPROVED	CHECKED	MATERIAL 材料	-	CHAMFER 一般面取	-	QUANTITY 個数				
△				T. A.	T. A.	TREATMENT 処理	-	FINISHING 仕上	-	-				
△						TREATMENT CONTACT 処理接点	-	DECENTRATION 偏芯	-					
△				DESIGNED	DRAWN	OVER 250 UP TO 1000	± 0.3	± 0.5	± 1.0	± 0.2	REMARK 適用 (機種名)			
△						OVER 63 UP TO 250	± 0.2	± 0.3	± 0.6	± 0.15		UNIT (mm)	-	SV-5026H
△				T. A.	T. T.	OVER 16 UP TO 63	± 0.1	± 0.2	± 0.4	± 0.1	SCALE	1 / 1	NAME	
△						OVER 0 UP TO 16	± 0.05	± 0.1	± 0.2	± 0.1				DATE
	DATE	EXCH NO.	REVISION 変更記事			TOLERANCES	(A)	B	C	S				